

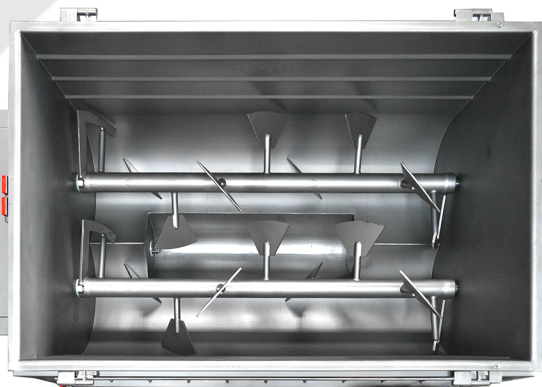

Butcher Boy[®] Machines



BUTCHER BOY 1000-66 Mixer-Grinder



MPBS
INDUSTRIES

Commercial Food Processing & Packaging Equipment

323-268-8514 800-421-6265 323-386-4058 (fax)

www.mpbs.com

Features:

- Stainless steel construction
- Fabricated to USDA standards
- O/A dimensions: +/- 87 L x 36 W x 70-76" H
- Grinding capacity: +/- 15000 lb per hour (using a 1/2" holes plate)
- Fully automatic feed
- High output grinder for fresh or tempered meat
- Hopper capacity: +/- 1000 lb mixing capacity
- Alan Bradley safety switches
- UL certified electronics

Standard Safety Features:

- Lockout
- Safety switch at tub grid cover
- Feed box cover switch
- Control voltage 24 VAC

Plate Size:

- Size 66 plate
 - 6" Barrel, 8-5/8" Plate

Motor:

- Grinding: 208/230/460V / 60 Hz / 3 Ø
 - Heavy-duty, 40 HP TEFC
- Mixing: 208/230/460V / 60 Hz / 3 Ø
 - 10 HP TEFC
- Conveyor: 208/230/460V / 60 Hz / 3 Ø
 - 5 HP TEFC
- Conforms to NEMA specifications

Motor Controls:

- All machines come with motor controls as standard equipment
- User to supply over-current protection

Includes:

- #1 Hopper with safety grid hinged on side
- 6" Adjustable legs to allow 22 to 28" clearance
- Spurt guard
- Spanner wrench
- Instruction manual and parts list

Weight:

- Shipping: +/- 2500 lbs

DIMENSIONS

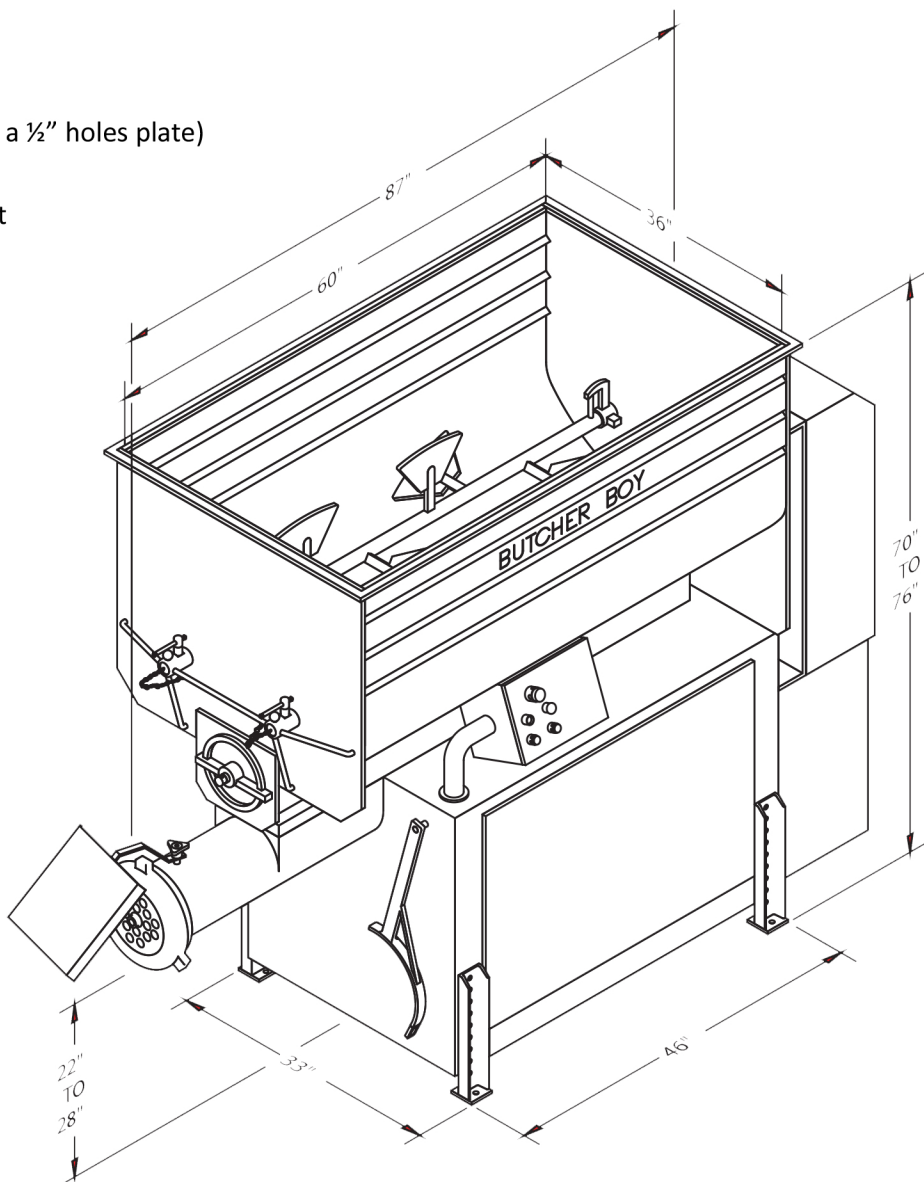

Options:

- Various hoppers
- Conveyor for easy loading
- Platform steps for operator to hand load machine
- Electrical

All specifications are subject to change without notice.

Manufactured by:
BUTCHER BOY MACHINES INT LLC
640 MULBERRY AVENUE
SELMER TN 38375

Distributed by:
MPBS INDUSTRIES
2820 EAST WASHINGTON BLVD
LOS ANGELES CA 90023
www.mpbs.com
contact@mpbs.com