

Pro-Saw® SS-16 Band Saw

THE ULTIMATE IN SAFETY AND SANITATION!

Commercial Features:

- ◆ All stainless steel construction
- ◆ Heavy-duty, 3 HP TEFC motor
- ◆ Right or Left hand
- ◆ USDA standards
- ◆ Standard Speed: 4000 FPM
- ◆ Revolutionary thickness gauge with steak guide for accurate cuts

Sanitation:

- ◆ 100% Stainless wheels
- ◆ Sealed wheel bearings
- ◆ Removable front and rear table for easy cleaning
- ◆ Removable wheel and blade cleaner system
- ◆ Disassemble main components easily without tools
- ◆ Deep tray
- ◆ 100% Washdown

Safety:

- ◆ 2 Hand safety start feature
- ◆ Thumb protector
- ◆ Magnetic safety switches in both wheel covers
- ◆ Lower tension handle
- ◆ Emergency stop button



Quality
Dependability
Service

We provide
technical support and
service for all machines
that we sell.



MPBS
INDUSTRIES

2820 East Washington Blvd. Los Angeles CA 90023
323-268-8514 ♦ 323-386-4058 (fax)
www.mpbsonline.com



Since 1938

Pro-Saw® SS-16 Band Saw

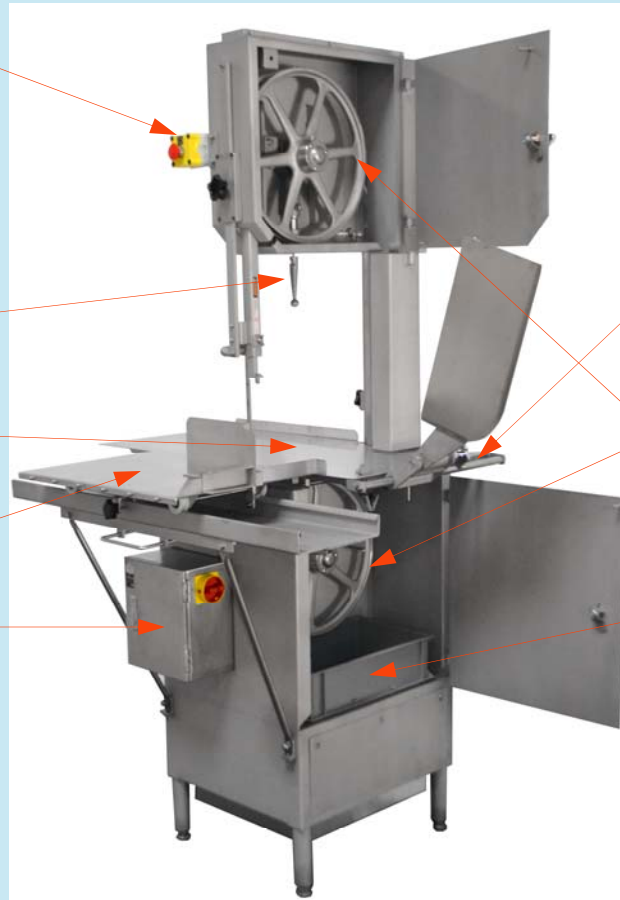

Emergency Stop Button

Tension Handle

Stationary Table

Roller Table Assembly

NEMA IV Box

Meat Gauge Assembly

Stainless Steel Wheels w/
Sealed Bearings

Scrap Box

Features:

- ◆ Table Lock Feature
- ◆ Adjustable Legs for precise leveling
- ◆ Sliding Table (4 Delrin rollers)
- ◆ Blade Speed: 4000 ft. per minute
- ◆ Cutting Area: 17" H x 1/4" - 15" D
- ◆ Heavy-Duty, 3 HP TEFC motor
- ◆ 208/220/440 V 60 Hz 3 Ø
- ◆ Starter with stop/start control box
- ◆ Weight: Net 390 lb Shipping 475 lb
- ◆ Full crating available—ask for details
- ◆ From .014 to .025 thickness 5/8" x 126" Blades

All specifications are subject to change without notice.

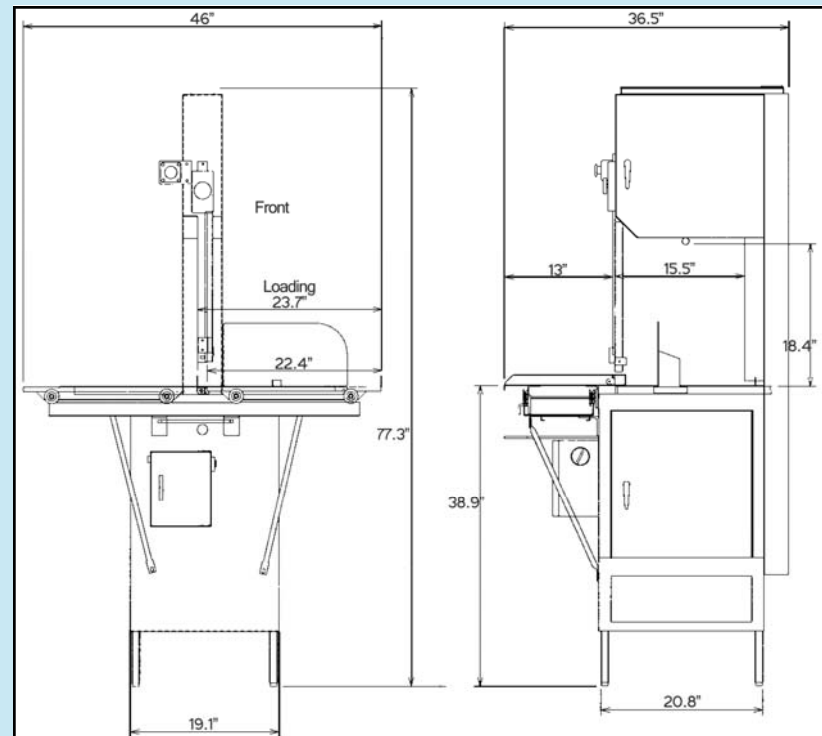

Commercial Food
Preparing Machines
E241294
13BS



Conforms to
NSF/ANSI 8



MPBS
INDUSTRIES

EST. 1938

Commercial Food Processing & Packaging Equipment