

Pro-Saw® SS-20 Band Saw

THE ULTIMATE IN SAFETY AND SANITATION!

Commercial Features:

- ◆ All stainless steel construction
- ◆ Heavy-duty, 5 HP TEFC motor
- ◆ Right or Left hand
- ◆ Standard speed: 4000 FPM
- ◆ Revolutionary thickness gauge
- ◆ Fabricated to USDA standards

Sanitation:

- ◆ 100% Stainless wheels
- ◆ Sealed wheel bearings
- ◆ Removable front and rear table for easy cleaning
- ◆ Removable upper wheel and blade cleaner system
- ◆ Disassemble main components easily without tools
- ◆ Deep tray
- ◆ 100% Washdown

Safety:

- ◆ 2 Hand safety start feature
- ◆ Thumb protector
- ◆ Magnetic safety switches on both wheel covers
- ◆ Lower tension handle
- ◆ Emergency stop button



**Quality
Dependability
Service**

We provide
technical support and
service for all machines
that we sell.



MPBS
INDUSTRIES

2820 East Washington Blvd. Los Angeles CA 90023
323-268-8514 ◆ 323-386-4058 (fax)
www.mpbsonline.com



Since 1938

Pro-Saw® SS-20 Band Saw

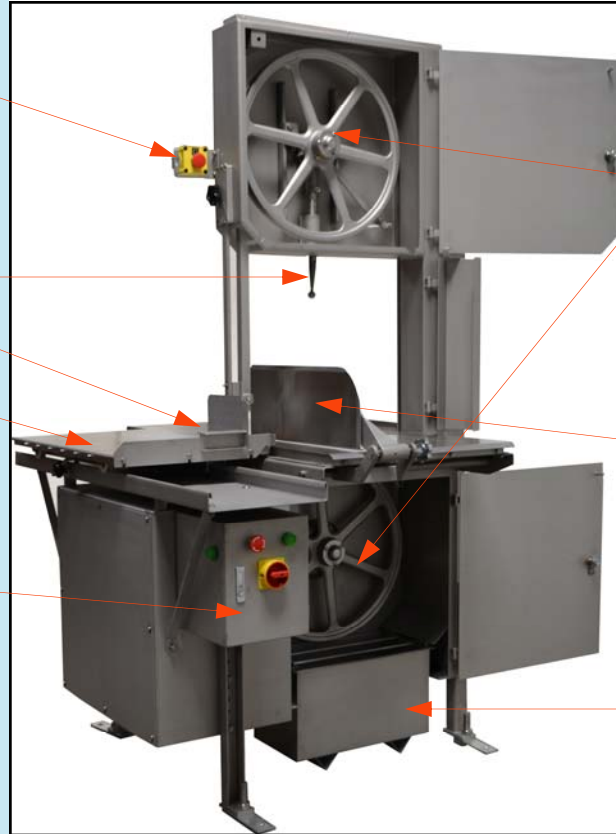

Emergency Stop Button

Tension Handle

Stationary Table

Roller Table Assembly

NEMA IV Box

Stainless Steel Wheels w/
Sealed Bearings

Meat Gauge Assembly

Scrap Box

Features:

- ◆ Table lock feature
- ◆ Adjustable legs for precise leveling
- ◆ Sliding table (4 Delrin rollers)
- ◆ Standard speed: 4000 ft. per minute
- ◆ O/A dimension: 44.5 x 56.6 x 86.5"
- ◆ Cutting Area:
 - ◆ Stationary: 20 x 27.4"
 - ◆ Removable: 20 x 19.7"
 - ◆ Carriage: 17.4 x 28.7"
 - ◆ Loading: 27.8"
- ◆ Loading dimension: 20 x 20"
- ◆ Heavy-duty, 5 HP TEFC motor
- ◆ 208/220/440 V / 60 Hz / 3 Ø
- ◆ Motor Controls: Starter with stop/start control box
- ◆ Weight: Net 700 lb Shipping 805 lb
- ◆ Full crating available—ask for details
- ◆ Saw blades thickness: 5/8" x 154" Blades

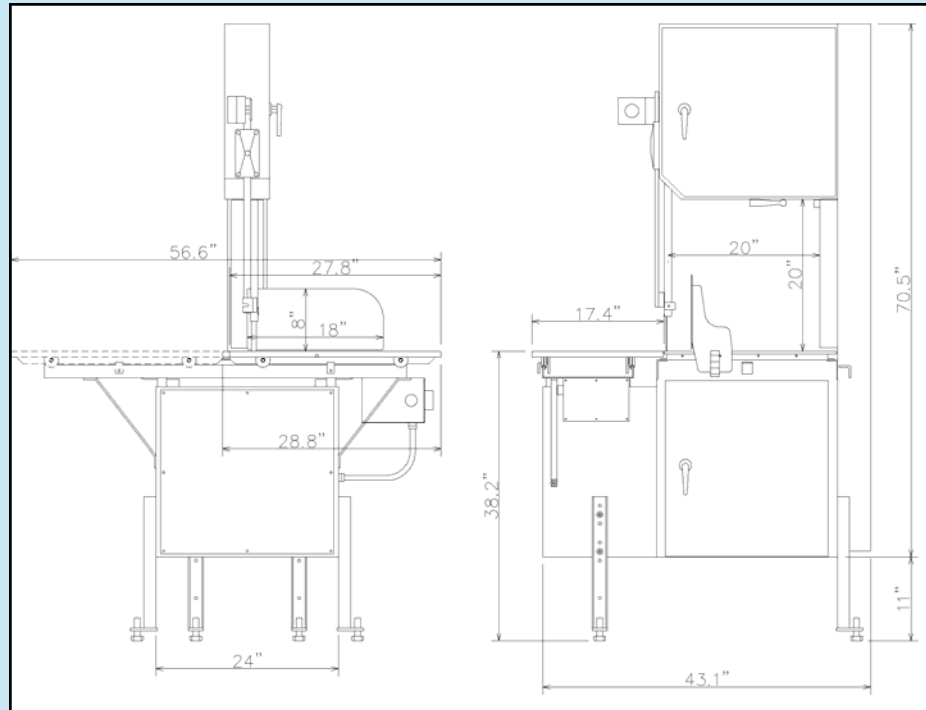

All specifications are subject to change without notice.

